

Freehub (12-Speed)  
**FH-MT510/MT510-B** For Disc Brake  
**SM-AX76 /AX76-B**

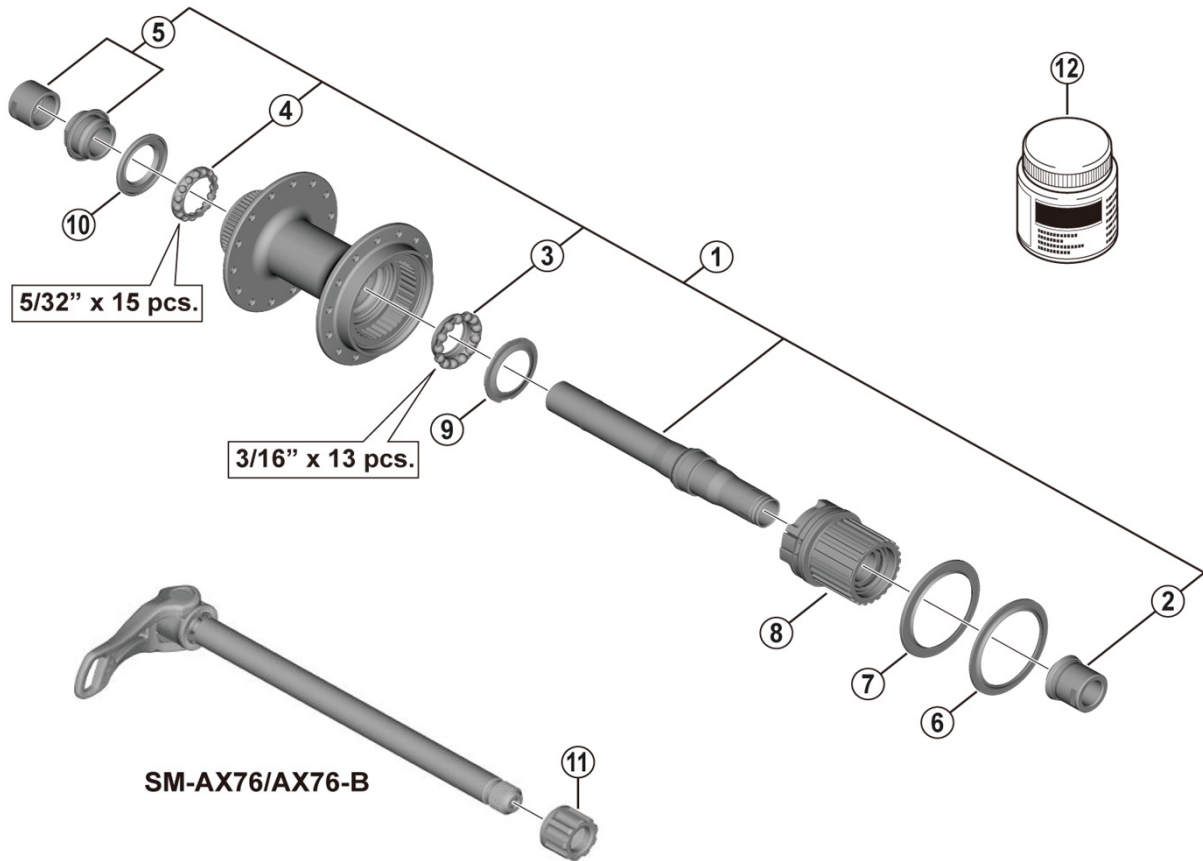

• Over Lock Nut Dimension: 142 mm (5-19/32") for FH-MT500 / 148 mm (5-13/16") for FH-MT500-B

ITEM NO.	SHIMANO CODE NO.	DESCRIPTION	INTERCHANGEABILITY	
			FH-MT500	FH-MT500-B
1	Y3GA98010	Complete Hub Axle for FH-MT510		
	Y0KD98010	Complete Hub Axle for FH-MT510-B		
2	Y3G198020	Right Hand Cap Unit		
3	Y3G198030	Right Hand Ball Retainer (3/16" x 13)	A	A
4	Y0CJ98030	Ball Retainer (5/32" x 15)	A	A
5	Y0KD98030	Left Hand Lock Nut & Cone w/Dust Cover		
6	Y3GD10000	Outer Seal Cap	A	A
7	Y3GD11000	Outer Seal Ring	A	A
8	Y0KD98040	Freewheel Body Unit	A	A
9	Y3G112000	Inner Cover	A	A
10	Y26D10000	Seal Ring	A	A
11	Y27Y02000	Fixing Nut (M12)		
12	Y3B980000	Grease for FREEHUB 50g	A	A

A: Same parts.

B: Parts are usable, but differ in materials, appearance, finish, size, etc.

Absence of mark indicates non-interchangeability.

Specifications are subject to change without notice.

Dec.-2019-4550

© Shimano Inc. ITP

**SHIMANO**